



Last version of this manual

IP1639EN•2023-05-12

Ditec



Ditec OBBI

Technical Manual

Swing gates automation

(translation of the original instructions)

Index

General safety precautions	25
Declaration of incorporation of partly completed machinery	26
UK Declaration of Conformity	27
1. Technical specifications	28
1.1 Operating instructions	29
1.2 Machinery Directive	29
2. Standard installation	30
3. Geared motor references	31
4. Installation	32
4.1 Preliminary checks	32
4.2 Geared motor installation	32
5. Electrical connections	36
6. Routine maintenance plan	37
Operating instructions	38
Manual release instructions	40

Legend



This symbol indicates instructions or notes relating to safety which require special attention.



This symbol indicates useful information for the correct operation of the product.

General safety precautions



ATTENTION! Important safety instructions. Please follow these instructions carefully.

Failure to observe the information given in this manual may lead to severe personal injury or damage to the equipment. Keep these instructions for future reference.

This manual and those for any accessories can be downloaded from www.ditecautomations.com

This installation manual is intended for qualified personnel only • Installation, electrical connections and adjustments must be performed by qualified personnel, in accordance with Good Working Methods and in compliance with the current regulations • Read the instructions carefully before installing the product. Wrong installation could be dangerous • Before installing the product, make sure it is in perfect condition.



The packaging materials (plastic, polystyrene, etc.) should not be discarded in the environment or left within reach of children, as they are a potential source of danger • Do not install the product in explosive areas and atmospheres: the presence of inflammable gas or fumes represents a serious safety hazard • Make sure that the temperature range indicated in the technical specifications is compatible with the installation site • Before installing the motorization device, make sure that the existing structure, as well as all the support and guide elements, are up to standards in terms of strength and stability. Verify the stability and smooth mobility of the guided part, and make sure that no risks of fall or derailment subsist. Make all the necessary structural modifications to create safety clearance and to guard or isolate all the crushing, shearing, trapping and general hazardous areas • The motorization device manufacturer is not responsible for failure to observe Good Working Methods when building the frames to be motorized, or for any deformation during use • The safety devices (photocells, safety edges, emergency stops, etc.) must be installed taking into account the applicable laws and directives, Good Working Methods, installation premises, system operating logic and the forces developed by the motorized door or gate • The safety devices must protect against crushing, cutting, trapping and general danger areas of the motorized door or gate. Display the signs required by law to identify hazardous areas • Each installation must bear a visible indication of the data identifying the motorized door or gate • Before connecting the power supply, make sure the plate data correspond to those of the mains power supply. An omnipolar disconnection switch with a contact opening distance of at least 3 mm must be fitted on the mains supply. Check that there is an adequate residual current circuit breaker and a suitable overcurrent cutout upstream of the electrical installation in accordance with Good Working Methods and with the laws in force • When requested, connect the motorized door or gate to an effective earthing system that complies with the current safety standards • Before commissioning the installation to the end user, make sure that the automation is adequately adjusted in order to satisfy all the functional and safety requirements, and that all the command, safety, and manual release devices operate correctly.



During maintenance and repair operations, cut off the power supply before opening the cover to access the electrical parts • The protection cover of the operator must be removed by qualified personnel only.



The electronic parts must be handled using earthed antistatic conductive arms. The manufacturer of the motorization declines all responsibility if component parts not compatible with safe and correct operation are fitted • Only use original spare parts for repairing or replacing products • The installer must supply all information concerning the automatic, manual and emergency operation of the motorized door or gate, and must provide the user with the operation and safety instructions

Declaration of incorporation of partly completed machinery

(Directive 2006/42/EC, Annex II-B)

We,
ASSA ABLOY Entrance Systems AB
Lodjursgatan 10
SE-261 44 Landskrona
Sweden,

declare, under our sole responsibility, that the type of equipment with the name:

Ditec OBBI Automation for swing gates

complies with the following directives and their amendments:

2006/42/EC Machinery Directive (MD), regarding the following essential health and safety requirements:

1.1.2, 1.1.3, 1.2.1, 1.2.2, 1.2.3, 1.2.4.2, 1.2.6, 1.3.9, 1.4.3, 1.7.2, 1.7.3, 1.7.4, 1.7.4.1, 1.7.4.2.

2014/30/EU Electromagnetic Compatibility Directive (EMCD)

2011/65/EU Restriction of Hazardous Substances (RoHS 2)

2015/863/EU Restriction of Hazardous Substances (RoHS Amendment 2)

Harmonised European standards which have been applied:

EN 61000-6-3:2007 + A1:2011 + AC:2012

EN 60335-1:2012 + AC:2014 + A11:2014 + A13:2017 + A1:2019 + A14:2019 + A2:2019 + A15:2021

Other standards or technical specifications which have been applied:

IEC 60335-1:2010 + C1:2010 + C2:2011 + A2:2013 + C1:2014 + A2:2016 + C1:2016

EN 12453:2017

The manufacturing process guarantees that the equipment complies with the technical documentation.

Responsible for the technical documentation:

Matteo Fino
BSP Ind channel & Gate Automation
Ditec S.p.A.
Largo U. Boccioni, 1
21040 Origgio (VA)
Italy

Signed on behalf of ASSA ABLOY Entrance Systems AB by:

Place	Date	Signature	Position
Origgio	2023-05-12	Matteo Fino	Head of Ind channel & Gate Automation



UK Declaration of Conformity

We:

ASSA ABLOY Entrance Systems AB
Lodjursgatan 10
SE-261 44 Landskrona
Sweden

Declare under our sole responsibility that the types of equipment with names:

Ditec OBBI Automation for swing gates

complies with the following directives and their amendments:

- Supply of Machinery (Safety) Regulations 2016
- Electromagnetic Compatibility Regulations 2016
- The Restriction of the Use of Certain Hazardous Substances in Electrical and Electronic Equipment Regulations 2012 (RoHS)

Harmonized European standards that have been applied:

EN 61000-6-3:2007 + A1:2011 + AC:2012

EN 60335-1:2012 + AC:2014 + A11:2014 + A13:2017 + A1:2019 + A14:2019 + A2:2019 + A15:2021

Other standards or technical specifications that have been applied:

IEC 60335-1:2010 + C1:2010 + C2:2011 + A2:2013 + C1:2014 + A2:2016 + C1:2016

EN 12453:2017

The manufacturing process ensures the compliance of the equipment with the technical file.

Responsible for technical file:

Matteo Fino
BSP Ind channel & Gate Automation
Ditec S.p.A.
Largo U. Boccioni, 1
21040 Origgio (VA)
Italy

Signed for and on behalf of ASSA ABLOY Entrance Systems AB by:

Place	Date	Signature	Position
Origgio	2023-05-12	Matteo Fino	Head of Ind channel & Gate Automation

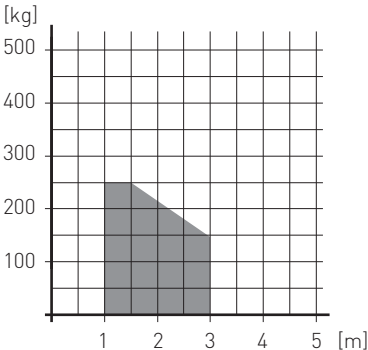

1. Technical specifications

	Ditec OBBI3BH
Power supply	24 V=
Absorption	3 A
Thrust	1500 N
Max run	350 mm
Opening time	25 s / 90°
Max. door weight	250 kg
Max. door width	3,0 m
Service class	3 - FREQUENTE (tested up to 150.000 cycles)
Intermittence	S2= 30 min (T= 25°C) S3= 50% (T= 25°C)
Cycles / hour *	30 (T= 25°C)
Continuous cycles **	28 (T= 25°C)
Temperature (T)	 -20°C +55°C (-35°C +55°C with NIO active)
Degree of protection	IP54
Control panel	LCU30H - LCU30HJ - LCU40H - LCU40HJ
Application m = leaf width kg = leaf weight	

i * Indicative cycles consider a time per opening/closing maneuver of 30 sec and pause time of 30 sec. Full cycle time of 120 sec.

** Indicative cycles consider a time per opening/closing maneuver of 30 sec and pause time of 2 sec. Full cycle time of 64 sec.

1.1 Operating instructions

Use: FREQUENT (for vehicle or pedestrian for single-family or multi-family with frequent use).

- Performance characteristics are to be understood as referring to the recommended weight (approx. 2/3 of maximum permissible weight). A reduction in performance is to be expected when the access is made to operate at the maximum permissible weight.
- Service class, running times, and the number of consecutive cycles are to be taken as merely indicative having been statistically determined under average operating conditions, and are therefore not necessarily applicable to specific conditions of use. During given time spans product performance characteristics will be such as not to require any special maintenance.
- The actual performance characteristics of each automatic access may be affected by independent variables such as friction, balancing and environmental factors, all of which may substantially alter the performance characteristics of the automatic access or curtail its working life or parts thereof (including the automatic devices themselves). When setting up, specific local conditions must be duly borne in mind and the installation adapted accordingly for ensuring maximum durability and trouble-free operation.

1.2 Machinery Directive

Pursuant to Machinery Directive (2006/42/EC) the installer who motorizes a door or gate has the same obligations as the manufacturer of machinery and as such must:

- prepare the technical file which must contain the documents indicated in Annex V of the Machinery Directive;
(The technical file must be kept and placed at the disposal of competent national authorities for at least ten years from the date of manufacture of the motorized door);
- draw up the EC Declaration of Conformity in accordance with Annex II-A of the Machinery Directive and deliver it to the customer;
- affix the EC marking on the motorized door in accordance with point 1.7.3 of Annex I of the Machinery Directive.

2. Standard installation

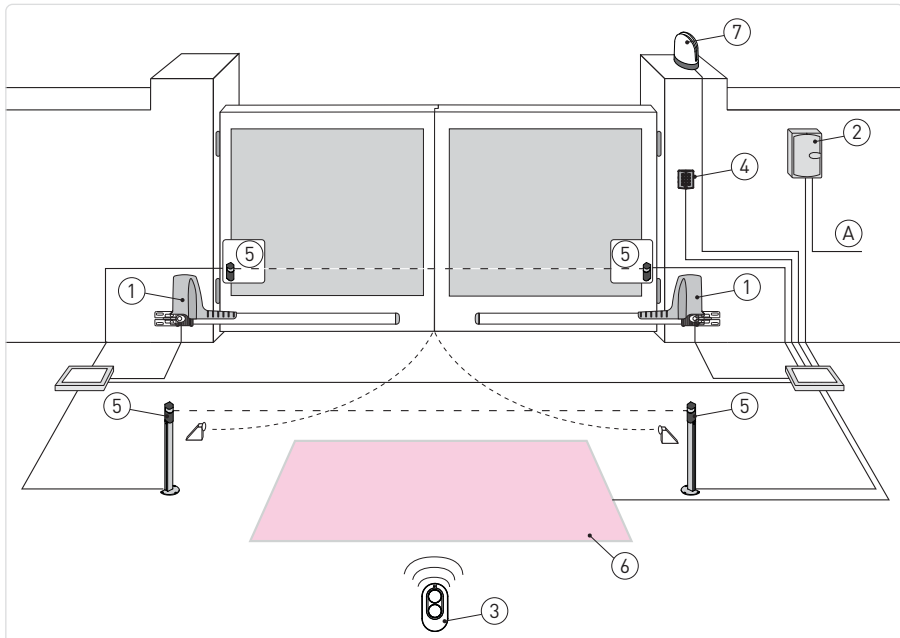

Ref.	Code	Description	Cable
A		Connector block (not supplied). Connect the power supply to an approved omnipolar switch with an opening distance of the contacts of at least 3mm (not supplied). The connection to the mains must be made via an independent channel, separated from the connections to command and safety devices.	
1	OBBI3BH	Gearmotor	2 x 1,5 mm ²
2	LCU30H-HJ LCU40H-HJ	Control panel	3G x 1.5 mm ²
3	ZEN	Transmitter	/
4	AXK4	Digital combination wireless keypad	/
	AXK5M	Wall-mounted key-operated selector switch with European cylinder	4 x 0.5 mm ²
	AXK5N	Semi-recessed key-operated selector switch with European cylinder	
	AXK5NM	Wall-mounted key-operated selector switch without cylinder	
AXK5NI	Semi-recessed key-operated selector switch without cylinder		
	AXR7	RFID reader unit	5 x 0.5 mm ²
5	LIN2	Photocells	4 x 0.5 mm ²
	LIN2B		
	AXP2		
	LAB4		
6	LAB9	Magnetic loop	2 x 1,5 mm ²
7	FLM	Flash clignotant	2 x 1 mm ²
	FL24	Antenna (integrated in the flashing light)	coax cable RG-58 (50 Ω)

3. Geared motor references

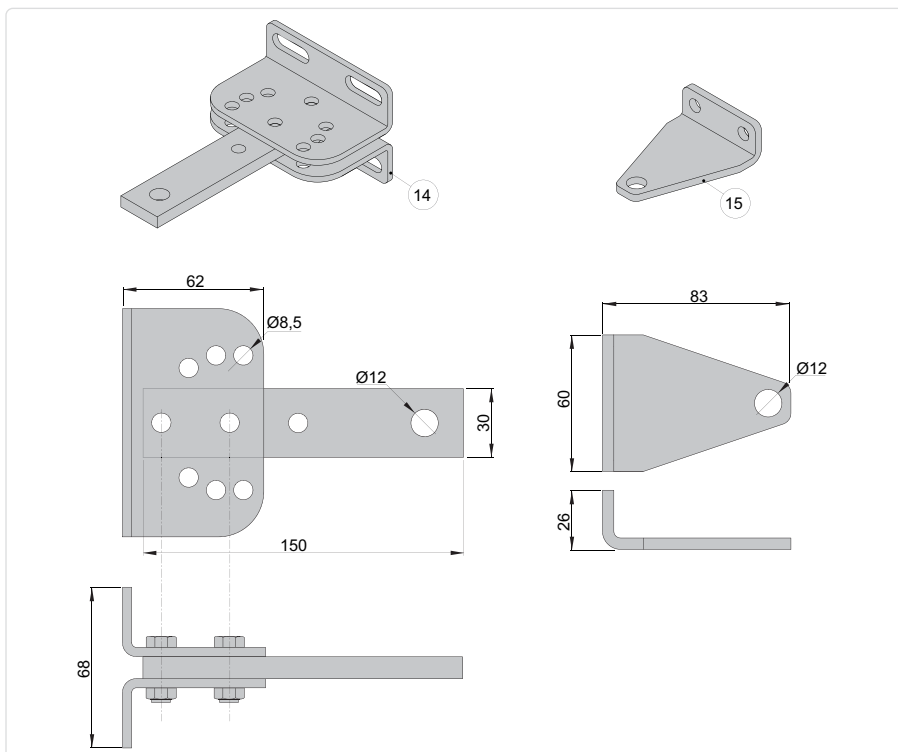
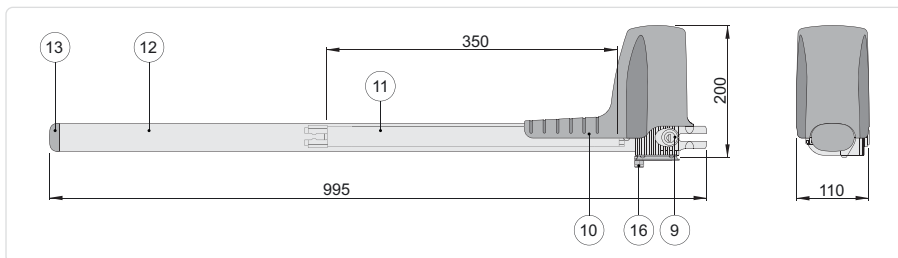

Ref.	Code	Description
9		Key release
10		Casing
11		Draft tube
12		Tube cover
13		Closing plug
14		Tail bracket
15		Head bracket
16		Cable guide sheat hooking bracket

4. Installation

The given operating and performance features can only be guaranteed with the use of DITEC accessories and safety devices.

Unless otherwise specified, all measurements are expressed in mm.

4.1 Preliminary checks

Check that the structure is sufficiently rugged and that the hinge pivots are properly lubricated. Provide an opening and closing stop.

4.2 Geared motor installation

Check the installation measurements on the basis of the distance between the hinge of the door wing and the corner of the pillar [C] and of the desired opening angle [D].

The installation measurements indicated in the table allow you to choose the values of [A] and [B] on the basis of the desired opening angle and in relation to the on site spaces and overall dimensions.

NOTE: The measurements [A] and [B] must be the same, in order to have a regular movement.

Increasing [A] decreases the coming up speed during opening.

Increasing [B] decreases the coming up speed during closing and improves burglar-proofing.

Reducing [B] increases the extent of gate opening.

Measurements [A] and [B] must in any case be compatible with the useful travel of the piston so that; if [A] is increased, [B] must be decreased and vice versa.

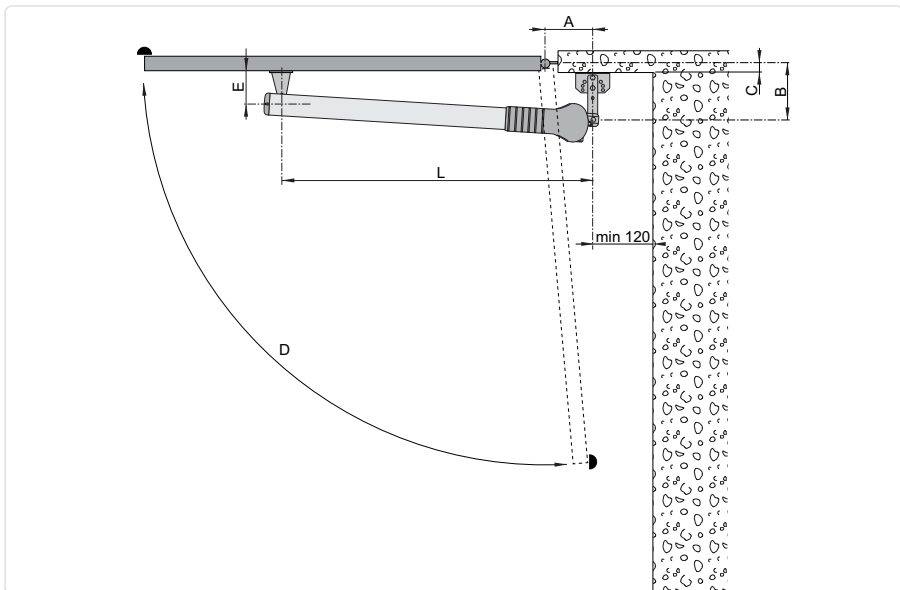

A	B	C max	D max	E	L
150	150	85	100°		
120	160	95	100°		
120	180	115	100°	75	910
160	120	55	110°		

- If the gearmotor opening direction needs to be modified, proceed as shown in the figure (example of motor transformation with opening direction from right to left).

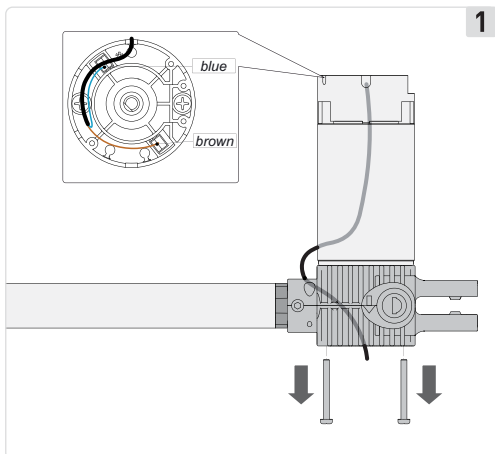

- Loosen the motor fastening screws.

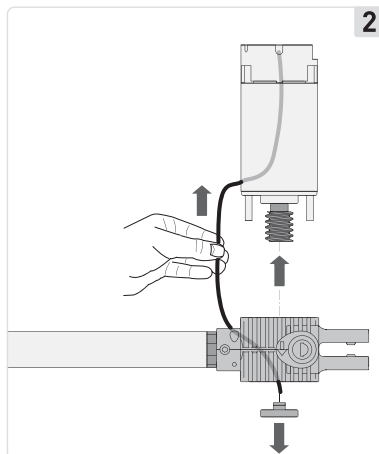

- Extract the motor and the reducer cap and unthread the motor cable.

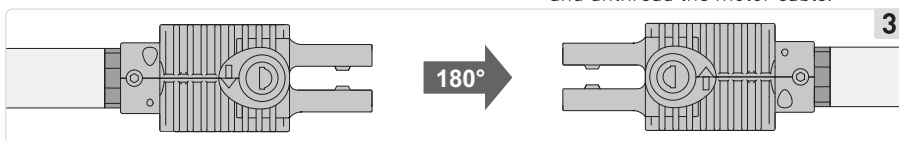

- Rotate the reduction gear by 180°.

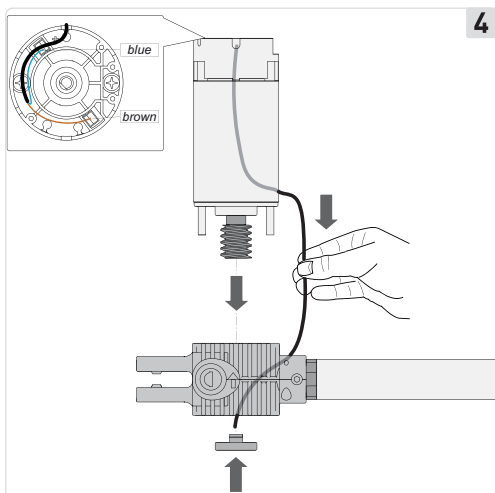

- With the reduction gear rotated, insert the motor and cap, and insert the cable.

WARNING: the motor must be assembled so that the cable remains on the side opposite the release

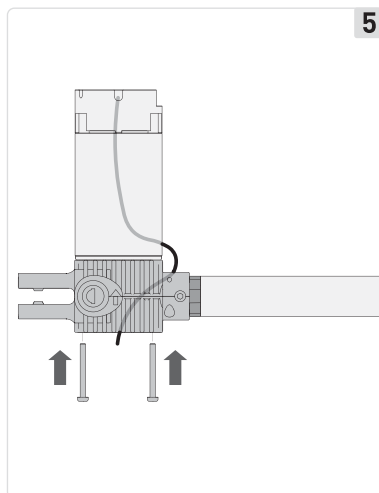

- Insert and fix the motor fastening screws.

- Fix the tail bracket [14], respecting measurements [A] and [B] on the basis of the desired opening angle [D].
- On the tail bracket there are holes that facilitate the assembly operation.
- Fix the piston to the rear bracket [14] with the pin [F] supplied.
- Extend the haulage tube completely [11] to its maximum length, then shorten it by approximately 20 mm.

WARNING: the stops must keep a 10 mm margin of tube stroke, in both the door wing closed and door wing open positions.

- With the gate completely closed, position the front bracket [15], check it is aligned with the rear bracket and fix it to the gate.
- Fix the piston to the front bracket with the pin [G] supplied. To work correctly, the gearmotors must be assembled with the motor casing at the top.
- Unblock the gearmotor and check (moving the gate manually) the entire stroke is free of interference. Slightly lubricate the front and rear articulated joints.

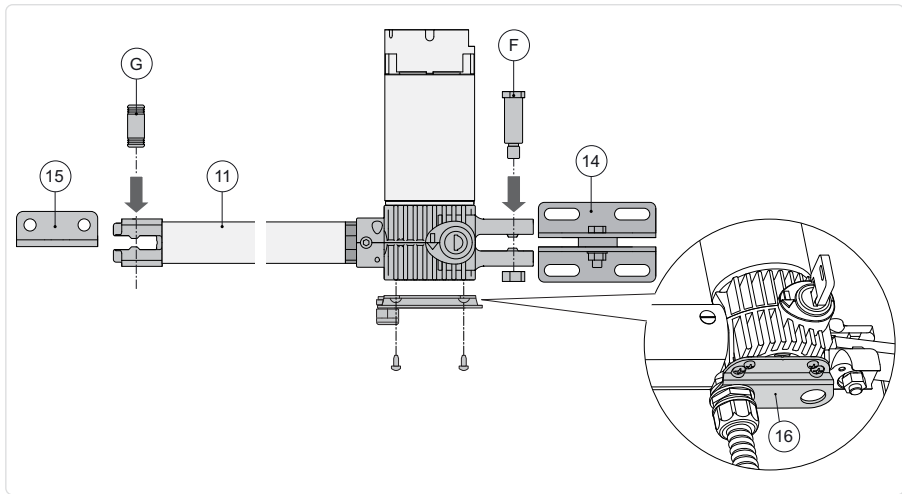

- Assemble the tube cover [12] with the cap [13] and seal, and fix it with the screws [H] supplied. Pay attention to the insertion direction. The slits on the closing cap [13] must be on the lower part in order to help the water to come out.
- Assemble the casing [10], fixing it with the screw [N], paying attention to the positioning of the cable.

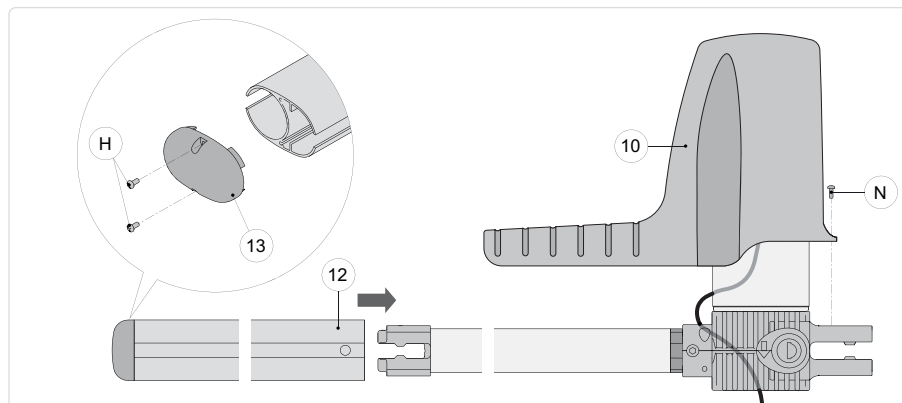

5. Electrical connections

Before connecting the power supply, make sure the plate data correspond to that of the mains power supply.

An omnipolar disconnection switch with minimum contact gaps of 3 mm must be included in the mains supply.

Check that upstream of the electrical installation there is an adequate residual current circuit breaker and a suitable overcurrent cutout.

The gearmotors OBB13BH can be connected to the LCU30H-HJ and LCU40H-HJ control panel. The electrical wiring and the start-up of the gearmotors OBB13BH are shown in figure and in the installation manuals of the LCU30H-HJ and LCU40H-HJ control panel.

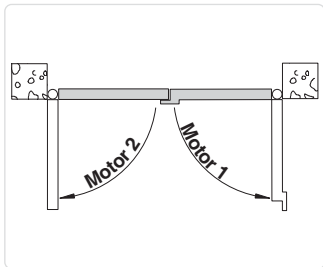

Motor 1	Control panel terminal board		
	31	32	33
OBB13BH	Blue	/	Black

Motor 2	Control panel terminal board		
	34	35	36
OBB13BH	Black	/	Blue

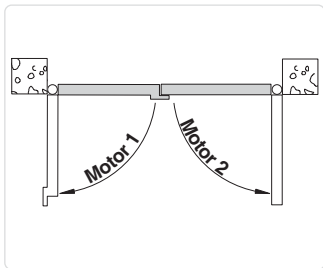

Motor 1	Control panel terminal board		
	31	32	33
OBB13BH	Black	/	Blue

Motor 2	Control panel terminal board		
	34	35	36
OBB13BH	Blue	/	Black

For complete control panel instructions see manual LCU40H-HJ - IP2246:



<https://www.ditecautomations.com/global/market-documents/QR/Multilanguages/LCU40H/DitecLCU40H.pdf>

For complete control panel instructions see manual LCU30H-HJ - IP2251:



<https://www.ditecautomations.com/global/market-documents/QR/Multilanguages/LCU30H/DitecLCU30H.pdf>

6. Routine maintenance plan

Perform the following operations and checks every 6 months according to intensity of use of the automation.

Disconnect the 230 V- power supply and batteries if present:

- Clean and lubricate, using neutral grease, the turning pins, the hinges of the gate and the drive screw.
- Check that fastening points are properly tightened.
- Check the electrical wiring is in good condition.

Reconnect the 230 V- power supply and batteries if present:

- Check the power adjustments.
- Check the good operation of all command and safety functions (photocells).
- Check the good operation of the release.
- If the LCU30H-HJ and LCU40H-HJ control panel is mounted, check for battery continuity by powering off and performing several manoeuvres in sequence. Upon test completion, power back on [230 V-].



NOTE: for spare parts, see the spares price list.

Operating instructions

General safety precautions for the user

ATTENTION! Important safety instructions • Please follow these instructions carefully • Failure to observe the information given in this manual may lead to severe personal injury or damage to the equipment • Keep these instructions for future reference.

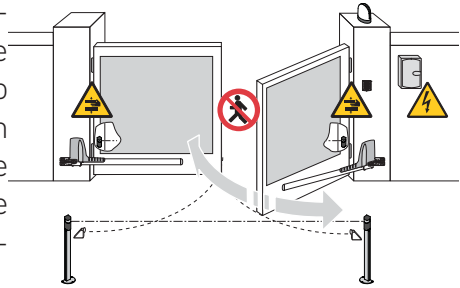

WARNING! Disconnect power supply before any cleaning or maintenance operation • This manual and those for any accessories can be downloaded from www.ditecautomations.com

These precautions are an integral and essential part of the product and must be supplied to the user. Read them carefully since they contain important information on safe installation, use and maintenance. These instructions must be kept and forwarded to all possible future users of the system • This product must be used only for the specific purpose for which it was designed. Any other use is to be considered improper and therefore dangerous. The manufacturer cannot be held responsible for any damage caused by improper, incorrect or unreasonable use • Avoid operating in the proximity of the hinges or moving mechanical parts. Do not enter within the operating range of the motorized door or gate while it is moving. Do not obstruct the motion of the motorized door or gate, as this may cause a dangerous situation • Lock and release the door or gate wings only when the motor is switched off. Do not enter within the action range of the door or gate wing(s) • In case of operation in “hold-to-run” (“dead man”) mode, the corresponding command devices must be located so to have direct and complete view of the door or gate during the maneuvers, away from any moving parts, at a minimum height of



1.5 m, and out of reach of the public • The motorized door or gate may be used by children over the age of 8 and by people with reduced physical, sensorial or mental abilities, or lack of experience or knowledge, as long as they are properly supervised or have been instructed in the safe use of the device and the relative hazards • Children must be supervised to make sure they do not play with the device, nor play or remain in the area of action of the motorized door or gate. Keep remote controls and/or any other command devices out of the reach of children, to avoid any accidental activation of the motorized door or gate • Cleaning and maintenance work intended to be done by the end user must not be carried out by children unless they are supervised. In the event of a product fault or malfunction, turn off the power supply switch. Do not attempt to repair or intervene directly.

Any repair or technical intervention must be carried out by qualified personnel. Failure to comply with the above may cause a dangerous situation • To ensure that the system works efficiently and correctly, the manufacturer's indications must be complied with and only qualified personnel must perform routine maintenance on the motorized door or gate. In particular, regular checks are recommended in order to verify that the safety devices are operating correctly • All installation, maintenance and repair work must be documented and made available to the user.

Manual release instructions

In the event of a fault or blackout, release any electric lock, insert the key and turn it anticlockwise (in the direction indicated by the arrow on the gearmotor). Manually open the gate.

To block the door wings again, turn the key clockwise (in the opposite direction to the arrow on the gearmotor). To facilitate the operation, move the door wing slightly.



WARNING: the door wing block and release operations must be performed with the motor idle.

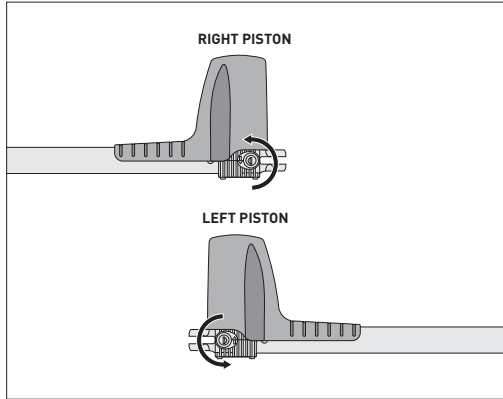

For any problems and/or information, contact the support service.

Installer's stamp	Operator
	Date of intervention
	Technician's signature
	Customer's signature

Intervention performed _____

DETACH AND DELIVER TO THE CUSTOMER

DETACH AND DELIVER TO THE CUSTOMER

IP1639EN

All the rights concerning this material are the exclusive property of ASSA ABLOY Entrance Systems AB. Although the contents of this publication have been drawn up with the greatest care, ASSA ABLOY Entrance Systems AB cannot be held responsible in any way for any damage caused by mistakes or omissions in this publication. We reserve the right to make changes without prior notice. Copying, scanning or changing in any way is expressly forbidden unless authorised in writing by ASSA ABLOY Entrance Systems AB.

 The crossed-out wheellie bin symbol indicates that the product should be disposed of separately from normal household waste. The product should be recycled in accordance with local environmental regulations for waste disposal. By separating a product marked with this symbol from household waste, you will help reduce the volume of waste sent to incinerators or land-fill and minimise any potential negative impact on human health and the environment.



ASSA ABLOY Entrance Systems AB
Lodjursgatan 10
SE-261 44, Landskrona
Sweden
© ASSA ABLOY