

Last version of this manual  
IP2373EN • 2022-11-10

# Ditec



## Ditec TS35

Technical Manual

### Automation for swing gates

(Translation of the original instructions)

# Contents

<b>General safety precautions</b>	3
<b>EC Declaration of Incorporation</b>	5
<b>1. Technical specifications</b>	7
1.1 Machinery Directive	8
1.2 Gearmotor dimensions	8
<b>2. Standard installation</b>	8
<b>3. Installation</b>	10
3.1 Preliminary checks	10
3.2 Fastening the brackets	11
3.3 Electrical connections	13
<b>4. Release instructions</b>	14
<b>5. Routine maintenance plan</b>	14
<b>6. Troubleshooting</b>	15
<b>7. Disposal</b>	15

## Key



This symbol indicates instructions or notes regarding safety, to which special attention must be paid.



This symbol indicates useful information for the correct operation of the product.

# General safety precautions



**ATTENTION!** Important safety instructions.

Please follow these instructions carefully. Failure to observe the information given in this manual may lead to severe personal injury or damage to the equipment.

Keep these instructions for future reference.

This manual and those for any accessories can be downloaded from [www.ditecautomations.com](http://www.ditecautomations.com).

This installation manual is intended for qualified personnel only • Installation, electrical connections and adjustments must be performed by qualified personnel, in accordance with Good Working Methods and in compliance with the current regulations • Read the instructions carefully before installing the product. Wrong installation could be dangerous • Before installing the product, make sure it is in perfect condition •



The packaging materials (plastic, polystyrene, etc.) should not be discarded in the environment or left within reach of children, as they are a potential source of danger • Do not install the product in explosive areas and atmospheres: the presence of inflammable gas or fumes represents a serious safety hazard • Make sure that the temperature range indicated in the technical specifications is compatible with the installation site • Before installing the motorization device, make sure that the existing structure, as well as all the support and guide elements, are up to standards in terms of strength and stability. Verify the stability and smooth mobility of the guided part, and make sure that no risks of fall or derailment subsist. Make all the necessary structural modifications to create safety clearance and to guard or isolate all the crushing, shearing, trapping and general hazardous areas • The motorization device manufacturer is not responsible for failure to observe Good Working Methods when building the frames to be motorized, or for any deformation during use • The safety devices (photocells, safety edges, emergency stops, etc.) must be installed taking into account the applicable laws and directives, Good Working Methods, installation premises, system operating logic and the forces developed by the motorized door or

gate • The safety devices must protect against crushing, cutting, trapping and general danger areas of the motorized door or gate. Display the signs required by law to identify hazardous areas. Each installation must bear a visible indication of the data identifying the motorized door or gate • Before connecting the power supply, make sure the plate data correspond to those of the mains power supply. An omnipolar disconnection switch with a contact opening distance of at least 3mm must be fitted on the mains supply. Check that there is an adequate residual current circuit breaker and a suitable overcurrent cutout upstream of the electrical installation in accordance with Good Working Methods and with the laws in force • When requested, connect the motorized door or gate to an effective earthing system that complies with the current safety standards • Before commissioning the installation to the end user, make sure that the automation is adequately adjusted in order to satisfy all the functional and safety requirements, and that all the command, safety, and manual release devices operate correctly •



During installation, maintenance and repair operations, cut off the power supply before opening the cover to access the electrical parts • The protection cover of the operator must be removed by qualified personnel only.



The electronic parts must be handled using earthed antistatic conductive arms. The manufacturer of the motorization declines all responsibility if component parts not compatible with safe and correct operation are fitted • Only use original spare parts for repairing or replacing products • The installer must supply all information concerning the automatic, manual and emergency operation of the motorized door or gate, and must provide the user with the operation and safety instructions.

# EC Declaration of Incorporation

We:  
ASSA ABLOY Entrance Systems AB  
Lodjursgatan 10  
SE-261 44 Landskrona  
Sweden

Declare under our sole responsibility that the type of equipment with name:

Ditec TS35AC          Automation for swing gates

Comply with the following directives and their amendments:

2006/42/EC          Machinery Directive (MD) for the following essential health and safety requirements: 1.1.2, 1.1.3, 1.2.1, 1.2.2, 1.2.3, 1.2.4.2, 1.2.6, 1.3.9, 1.4.3, 1.7.2, 1.7.3, 1.7.4, 1.7.4.1, 1.7.4.2.  
2014/30/EU          Electromagnetic Compatibility Directive (EMCD)  
2011/65/EU          Restriction of hazardous substances (RoHS 2)  
2015/863/EU          Restriction of hazardous substances (RoHS 2 Amendment)

Harmonized European standards that have been applied:

EN 61000-6-3:2007 + A1:2011 + AC:2012  
EN 60335-1:2012 + AC:2014 + A11:2014 + A13:2017 + A1:2019 + A14:2019 + A2:2019

Other standards or technical specifications that have been applied:

IEC 60335-1:2010 + C1:2010 + C2:2011 + A2:2013 + C1:2014 + A2:2016 + C1:2016  
EN 12453:2017

The manufacturing process ensures the compliance of the equipment with the technical file.

The equipment must not be used until the final installed automatic entrance system has been declared in compliance with the Machinery Directive 2006/42/EC.

Responsible for technical file:

Matteo Fino  
Business Area PGA  
Ditec S.p.A.  
Largo U. Boccioni, 1  
21040 Origgio (VA)  
Italy

Signed for and on behalf of ASSA ABLOY Entrance Systems AB by:

Place	Date	Signature	Position
Origgio	2022-11-10	Matteo Fino	Head of Ind channel & Gate Automation



# UK Declaration of Conformity

We:

ASSA ABLOY Entrance Systems AB  
Lodjursgatan 10  
SE-261 44 Landskrona  
Sweden

Declare under our sole responsibility that the types of equipment with names:

Ditec TS35AC          Automation for swing gates

Comply with the following directives and their amendments:

- Supply of Machinery (Safety) Regulations 2016
- Electromagnetic Compatibility Regulations 2016
- The Restriction of the Use of Certain Hazardous Substances in Electrical and Electronic Equipment Regulations 2012 (RoHS)

Harmonized European standards that have been applied:

EN 61000-6-3:2007 + A1:2011 + AC:2012

EN 60335-1:2012 + AC:2014 + A11:2014 + A13:2017 + A1:2019 + A14:2019 + A2:2019

Other standards or technical specifications that have been applied:

IEC 60335-1:2010 + C1:2010 + C2:2011 + A2:2013 + C1:2014 + A2:2016 + C1:2016

EN 12453:2017

The manufacturing process ensures the compliance of the equipment with the technical file.

Responsible for technical file:

Matteo Fino  
BSP Ind channel & Gate Automation  
Ditec S.p.A.  
Largo U. Boccioni, 1  
21040 Origgio (VA)  
Italy

Signed for and on behalf of ASSA ABLOY Entrance Systems AB by:

Place	Date	Signature	Position
Origgio	2022-11-10	Matteo Fino	Head of Ind channel & Gate Automation



# 1. Technical specifications

Power supply	230 V~ - 50 / 60 Hz
Max absorption	1,5 A
Motor type	230 V~
Power absorbed	330 W
Capacitor	8 $\mu$ F
Max thrust	3500 N
Maximum stroke	400 mm
Opening time	18-22 s / 90°
Intermittence	S2= 10min S3= 30%
Service class	FREQUENT - up to 100,000 cycles
Operating temperature	 -20°C +55°C
Degree of protection	IP33
Electronic panel	LCA70 - LCA80
Dimensions (mm)	1182x93x174
Weight (kg)	4,00

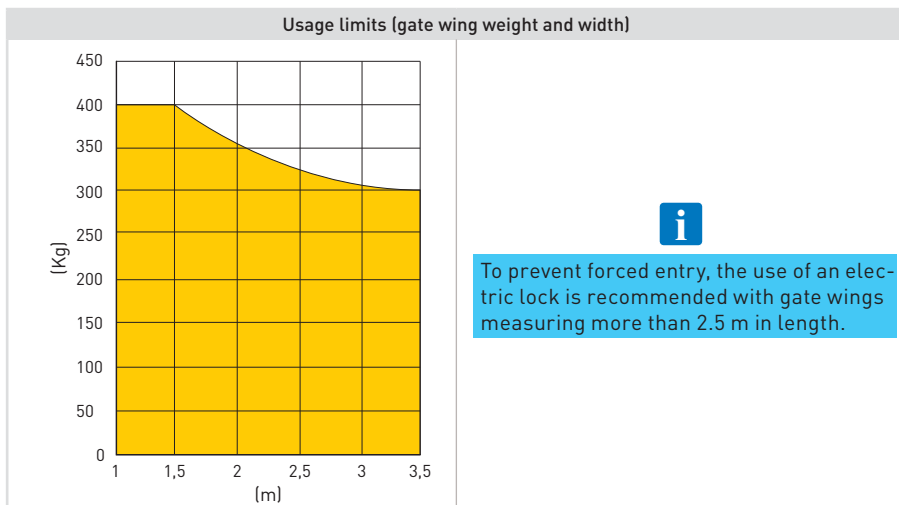

## 1.1 Machinery Directive

Pursuant to the Machinery Directive (2006/42/EC), the installer who motorises a door or gate has the same obligations as the manufacturer of machinery and as such must:

- prepare the technical data sheet which must contain the documents indicated in Annex V of the Machinery Directive;
- [the technical data sheet must be kept and placed at the disposal of competent national authorities for at least ten years from the date of manufacture of the motorised door or gate];
- draw up the EC Declaration of Conformity in accordance with Annex II-A of the Machinery Directive and deliver it to the customer;
- affix the EC marking on the motorised door or gate, in accordance with point 1.7.3 of Annex I of the Machinery Directive.

## 1.2 Gearmotor dimensions

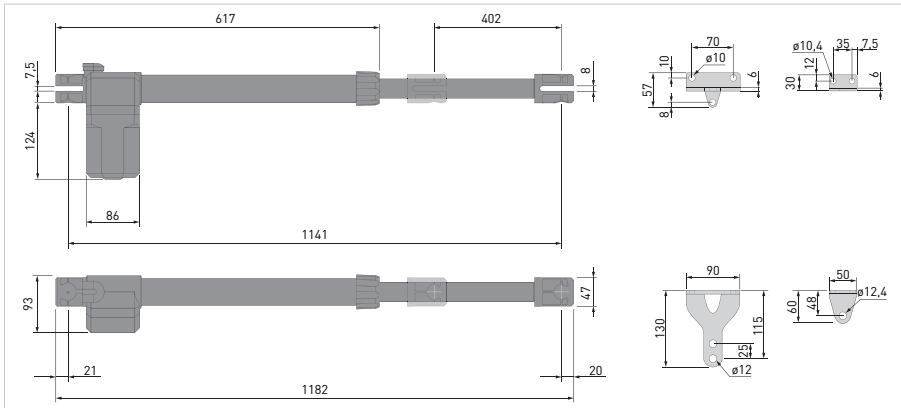

## 2. Standard installation

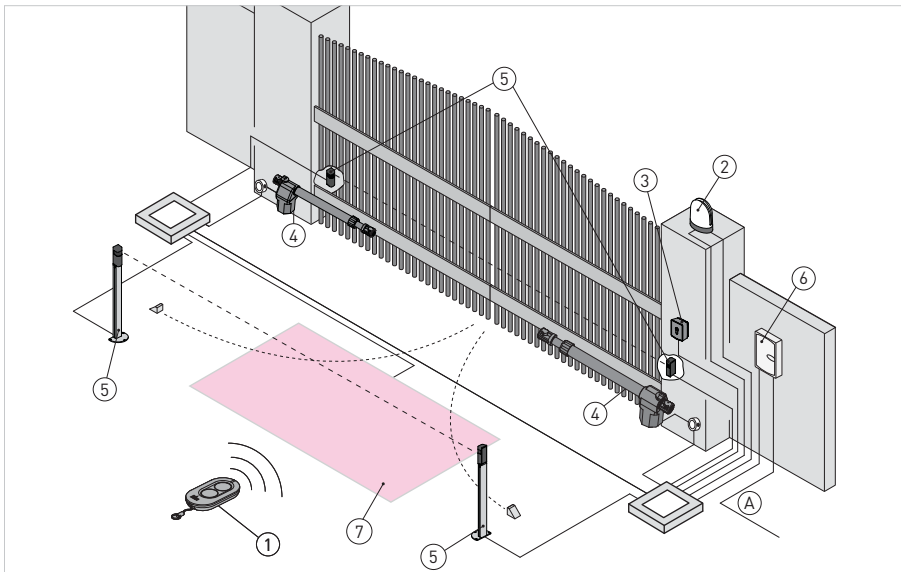



Ref.	Code	Description	Cable
1	ZEN	Transmitter	/
2	FLM	Flashing light	2 x 1 mm <sup>2</sup>
	FL24	Antenna (integrated in the flashing light)	coaxial RG-58 (50 Ω)
3	AXK4	Radio digital combination keypad	/
	AXK5M	Key-operated selector switch on wall	4 x 0.5 mm <sup>2</sup>
	AXR5I	Key-operated selector switch on wall semi-recessed	
	AXK5NM	Selector switches without cylinder on wall	
	AXK5NI	Selector switches without cylinder on wall semi-recessed	
	AXR7	Transponder	5 x 0.5 mm <sup>2</sup>
A		Connect the power supply to a type-approved omnipolar switch (not supplied), with a contact opening distance of at least 3 mm. Connection to the mains must be via an independent channel, separated from the connections to the command and safety devices.	
4	TS35	Automazione per cancelli a battente	4 x 1,5 mm <sup>2</sup>
5	LIN2	Photocells	4 x 0,5 mm <sup>2</sup>
	LIN2B	Photocells	
	AXP2	Photocells	
	LAB4	IP55 Photocells	
6	LCA70	Control panel installation manual for automations with one or	3G x 1,5 mm <sup>2</sup>
	LCA80	two 230 V- motors	
7	LAB9	Magnetic loop detector	2 x 1,5 mm <sup>2</sup>

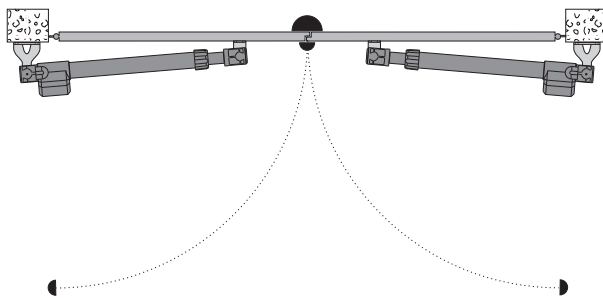

Left wing (TS35ACS)

Right wing (TS35ACD)



The gearmotors are left and right and are different from each other.

# 3. Installation

The declared operating and performance features can only be guaranteed with the use of Ditec accessories and safety devices.

## 3.1 Preliminary checks

Make sure the gate structure is sturdy and the hinges are lubricated and smooth. Install a stop in the open and closed positions (the mechanical structural elements must be compliant with the requirements of the standard EN12604). Check that the installation measurements are correct in relation to the distance between the hinge of the wing and the corner of the pillar [C] and the desired opening angle [D].

**i** The automation fastening point varies according to the space available and the gate to be automated. The installer must therefore choose the best solution to ensure that the system works correctly in each individual situation.

The installation measurements indicated in the table allow you to choose the values of [A] and [B] on the basis of the required opening angle and in relation to the on-site spaces and overall dimensions. Increasing measurement [A], you reduce the opening approach speed. Reducing measurement [B], you increase the gate opening angle. Measurements [A] and [B] must, however, be compatible with the effective piston stroke

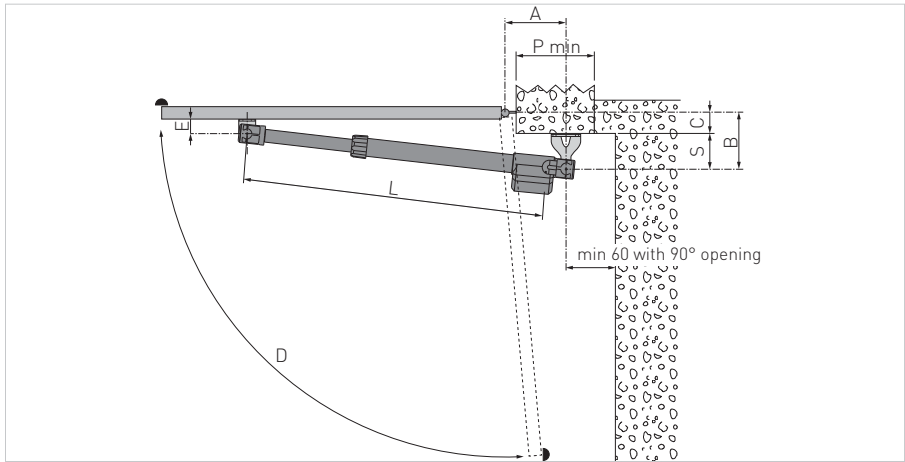

Tab. 3.1

A	B	C	S	D	E	L	P min
150	130	15	115	110°	46	1120	170
160	120	30	90	105°			180
160	160	45	115	100°			180
100	165	50	115	90°			120
130	160	70	90	95°			150
120	200	85	115	95°			140
150	200	85	115	90°			170
130	190	100	90	95°			150
130	220	105	115	90°			150

**i** Unless otherwise specified, all measurements are expressed in mm.

## 3.2 Fastening the brackets

- Fasten the tail bracket ①, ensuring that the measurements [A] and [B] are correct for the desired opening angle [D] (see tab. 3.1).

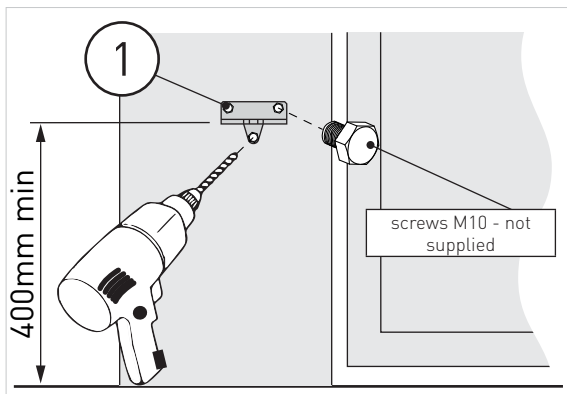

- Fasten the piston to the tail bracket ① with the pin (F) included.

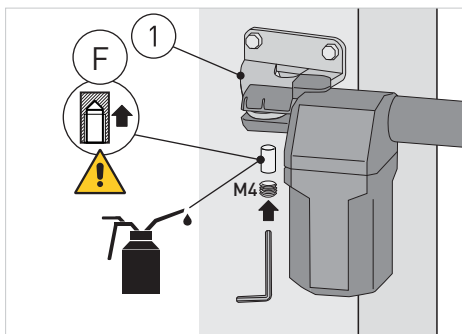
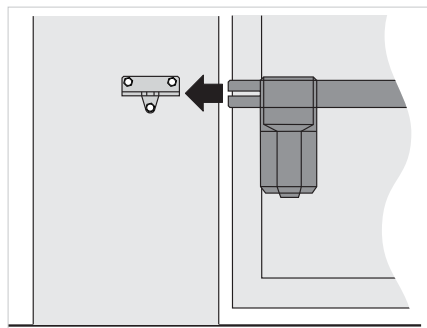

- With the gate closed, extend the actuator tube completely ③, unscrewing it to reach its maximum length, and then re-tighten by one complete turn as shown in the figure.

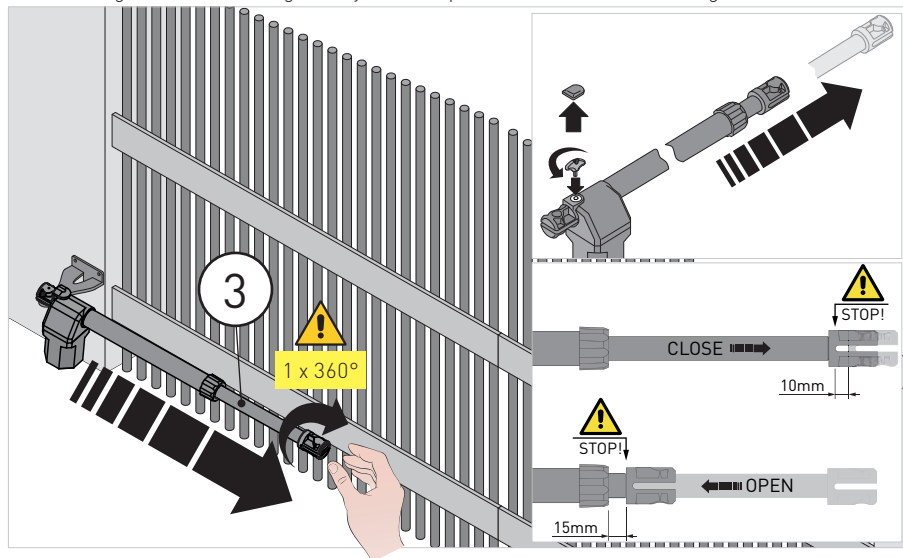

- Install the gear motor so that it is inclined by an angle of approximately 1°.

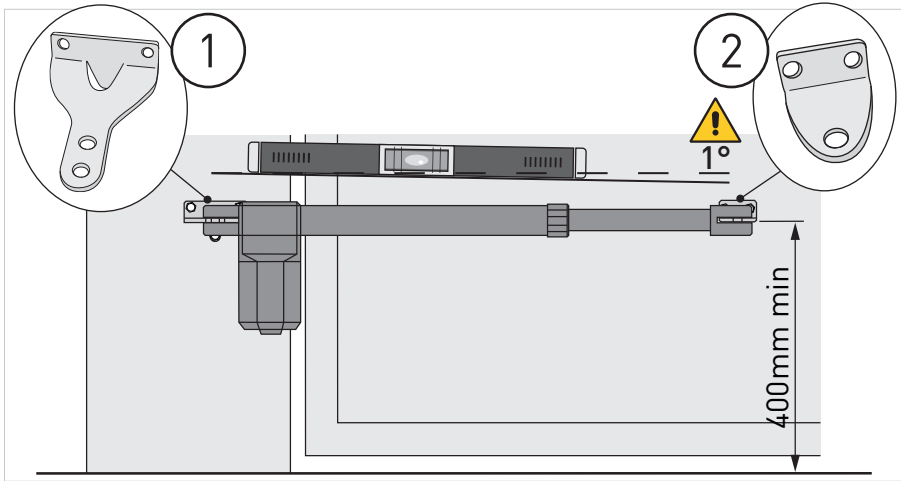

- Fit the head bracket (2) and fasten the piston to the head bracket with the pin (F) included.
- Unlock the gear motor and check, by moving the gate manually, that the gate moves freely

**i** To work correctly, the gear motors must be assembled with the motor casing at the bottom.

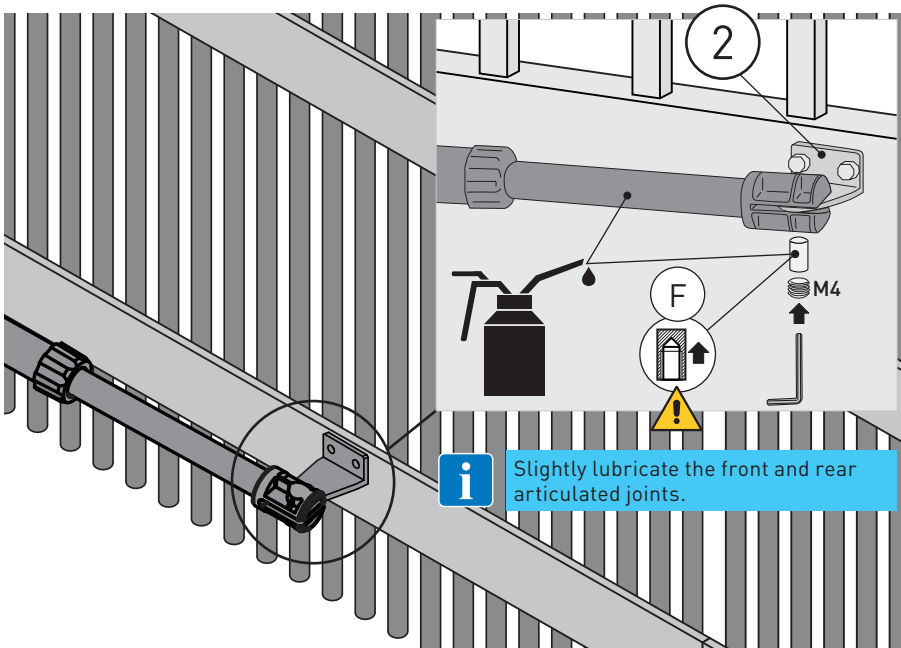

**i** Slightly lubricate the front and rear articulated joints.

throughout its entire stroke without impediment.

### 3.3 Electrical connections

The gear motors TS35AC may be connected to the LCA70 and LCA80 electronic control panels. The electrical connections and the procedure for setting up Ditec TS35 gear motors are illustrated in the figure and in the installation manuals of the LCA70 (-> link) and LCA80 (-> link) electronic control panels.

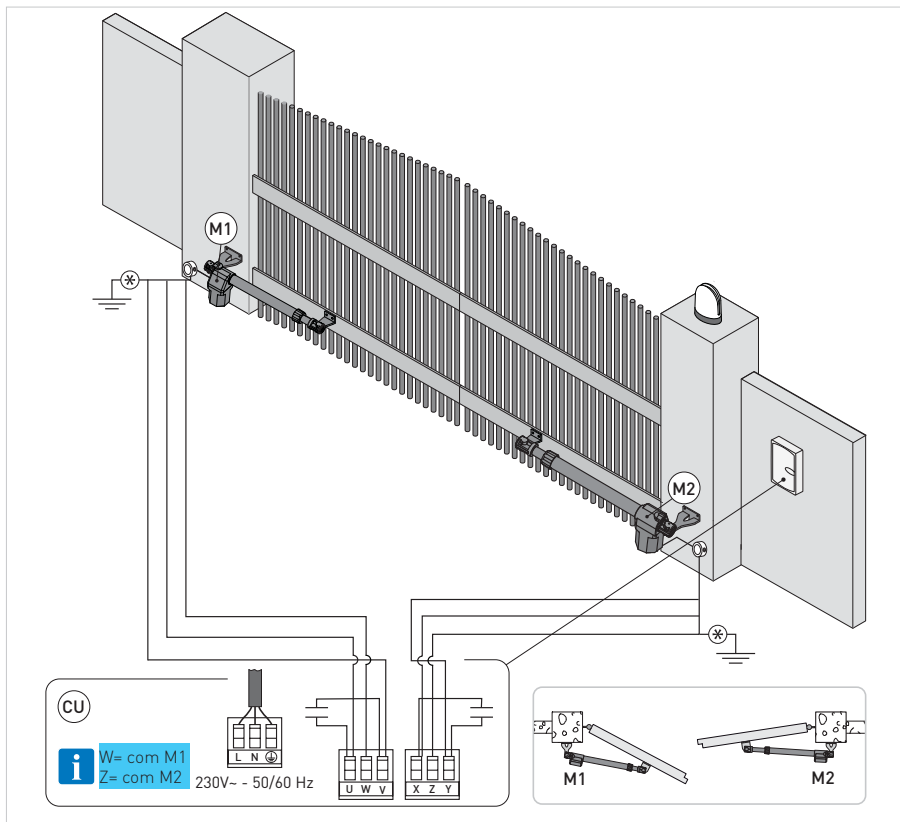

**M1** Gearmotor with closure delay

**M2** Gearmotor with opening delay

**CU** Control unit

**V/Y** BLACK

**U/X** BROWN

**W/Z** GREY

**\*** YELLOW/GREEN

## 4. Release instructions

In the event of a fault or a power failure, open the window, insert the key in the relative lock and turn it counterclockwise (as indicated by the arrow). Release the electric lock (if present). Manually open the gate. To lock the gate again, close the hatch, turn the key anticlockwise and remove the key.



**WARNING:** the gate lock and release operations must be performed with the motor idle. Do not enter within the operating range of the gate.

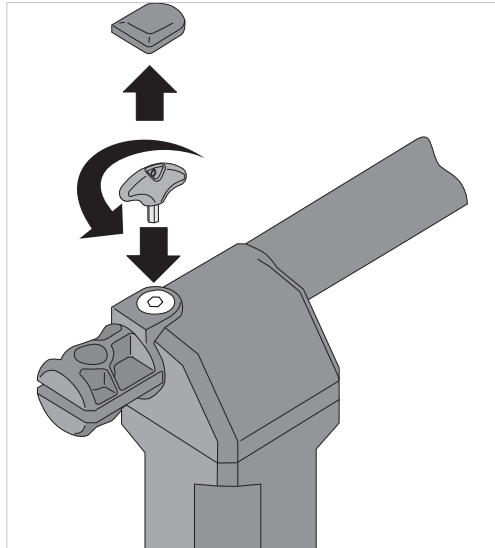

## 5. Routine maintenance plan

Carry out the following operations and checks every 6 months or 36.000 cycles.

Disconnect the 230V~ power supply:

- Clean and lubricate the gate rotation pins, hinges and drive screw with neutral grease.
- Check the resistance of the fixing points.
- Check the electrical connections are in good condition.

Reconnect the 230V~ power supply:

- Check the power adjustment.
- Check all the commands and safety functions (photocells) are operating correctly.
- Check the release system is working correctly.



**NOTE:** for spare parts, refer to the spares price list.

## 6. Troubleshooting

Problem	Possible cause	Operation
The gate doesn't open or close.	No power supply.	Make sure the mains supply is active.
	Gearmotor released.	See the release instructions.
	Photocells occupied.	Check the photocells are clean and operating correctly.
	Permanent STOP command.	Check the STOP command or the control panel.
	Faulty selector.	Check the selector or control panel.
	Faulty remote control.	Check the condition of the batteries.
Il cancello apre ma non chiude.	Electric lock not working.	Check the lock is positioned and working correctly.
	Photocells occupied.	Check the photocells are clean and operating correctly.

## 7. Disposal



The packaging components (cardboard, plastic, etc.) must be separated out for recycling. Refer to the local disposal regulations before proceeding.

The packaging materials must not be discarded in the environment or left within reach of children, as they are a potential source of danger.

All the rights concerning this material are the exclusive property of ASSA ABLOY Entrance Systems AB. Although the contents of this publication have been drawn up with the greatest care, ASSA ABLOY Entrance Systems AB cannot be held responsible in any way for any damage caused by mistakes or omissions. We reserve the right to make changes without prior notice. Copying, scanning or changing in any way is expressly forbidden unless authorised in writing by ASSA ABLOY Entrance Systems AB.

 The crossed-out wheeled bin symbol indicates that the product should be disposed of separately from household waste. The product should be handed in for recycling in accordance with local environmental regulations for waste disposal. By separating a marked item from household waste, you will help reduce the volume of waste sent to incinerators or landfill and minimize any potential negative impact on human health and the environment.



ASSA ABLOY Entrance Systems AB  
Lodjursgatan 10  
SE-261 44, Landskrona  
Sweden  
© ASSA ABLOY